

Installation Guide / Manual - TEN XXL Screen

TEN(XXL)

Warning

All products are thoroughly inspected and fully tested operational in factory. We accept no liability whatsoever for any losses due to improper operation, or any unauthorized alternation. All trademarks contained in this installation guide are the property of their respective owners.

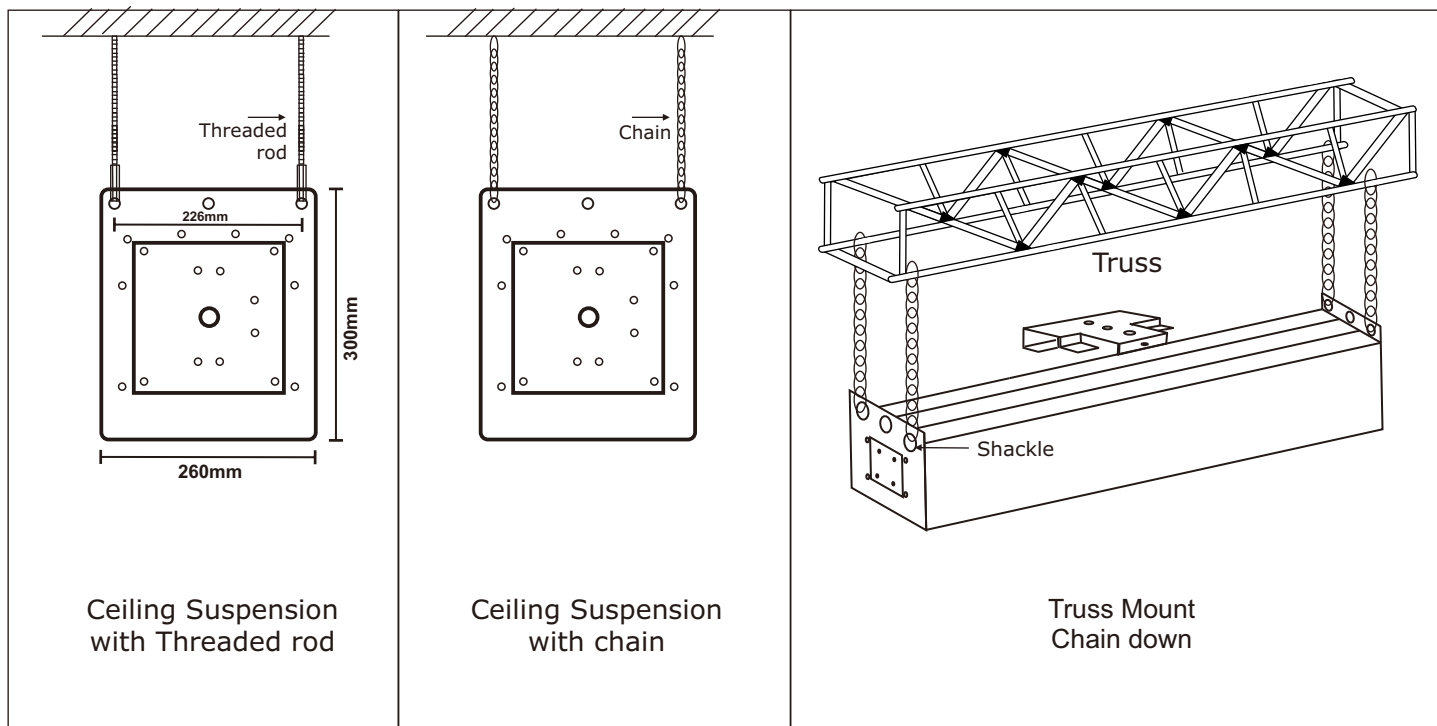

Accessories Included:

<p>Setting button</p> <p>Front</p> <p>Back</p>	<p>AVA-316-RF 15-Ch Radio-Frequency Remote</p>
<p>Front View</p> <p>PCB</p>	<p>MPC-852 Motor/Power Controller with Radio Frequency Receiver</p>
<p>Front</p> <p>Back</p> <p>Surface Box</p>	<p>AVA-200+ Touch-Contact Switch</p>

Wiring Diagram

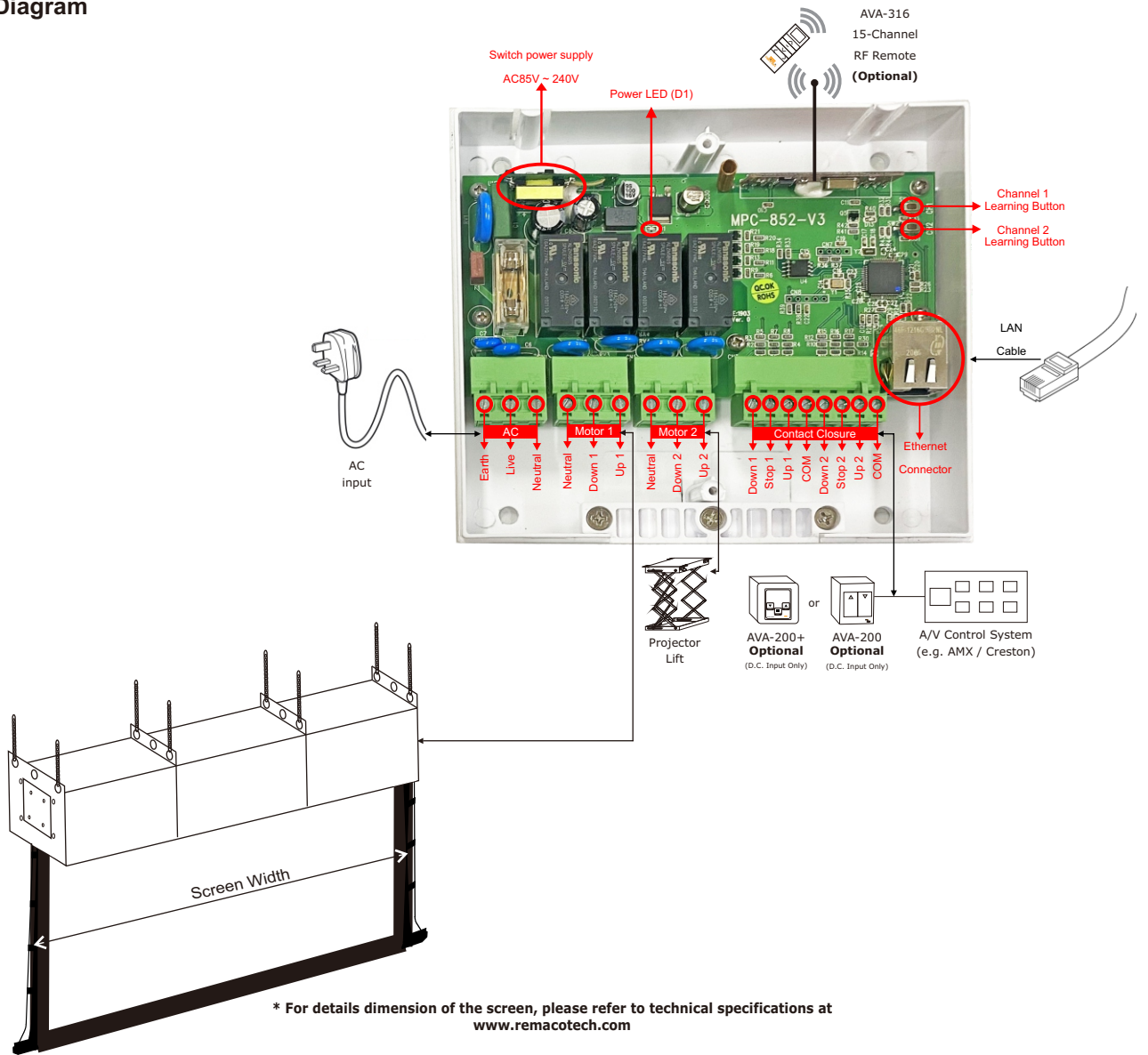

Connection	Application
Power	<p>Connect to a 230V power supply.</p> <p>AC Power Input</p> <p>Earth (Green) Live (Red) Neutral (Blue)</p>
Controlled Equipments	<p>For connection to up to 2 electrical motor powered equipments capable of bi-directional movements.</p> <p>Motor 1 Motor 2</p> <p>N D1 UP1 N D2 Up2</p> <p>Projector Screen</p> <p>Projector Lift</p> <p>Neutral (Blue) Down (Black) Up (Brown)</p> <p>Neutral (Blue) Down (Black) Up (Brown)</p>

Connection	Application
<p>Contact Closure (Momentary)</p>	<p>For control by an A/V control system (e.g. AMX or Creston) or a Touch-Contact Switch (Remaco AVA-200+)</p> <p>* For this zero voltage Contact Closure, any DC voltage exceeding 3V might damage the MPC</p> <p>* Works on momentary contact closure only. (Dry contact, normally open)</p> <div data-bbox="510 380 1308 851" style="text-align: center;"> <p>AVA-200+</p> <p>Up (Purple)</p> <p>Down (Pink)</p> <p>Stop (Grey)</p> <p>Common (Orange)</p> </div>

To set screen to your desired "up" and "down" positions.

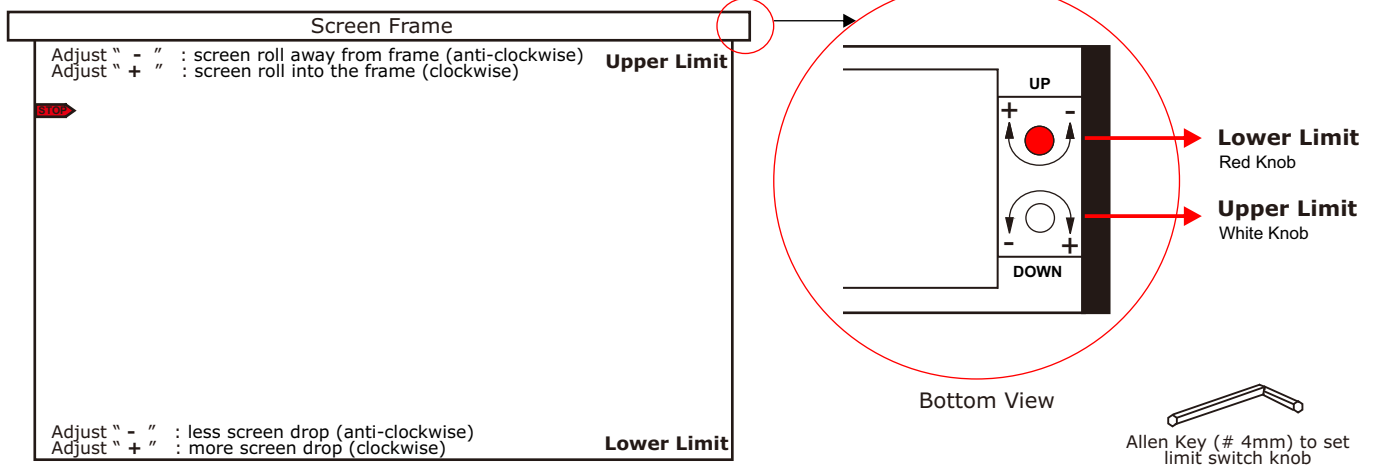

To set screen to your desired "up" and "down" positions.

Important Note

The upper limit and lower limit of the screen had been preset in factory. Any adjustment to these 2 limit switches may cause damages to the screen fabric. If adjusted, it will cause the following problems:

- The screen will roll into the frame and stop by force and not by the Upper Limit switch. This will cause overheating of motor which unable the screen to operate properly.
- The depression of the bottom bar onto the fabric will cause horizontal mark on screen surface.
- Adjusting the Lower Limit of the screen any lower than beyond the STOP sticker may cause the fabric to drop off

Disclaimer

Any adjustment to these 2 limit switches will void the warranty for the screen and Remaco will hold no responsibility for any damages to it. Please consult us if it is necessary to do any adjustment to the limit switch.

OPTION 1

MPC-851 compatible with AVA-316 15-Channel Radio Frequency Remote

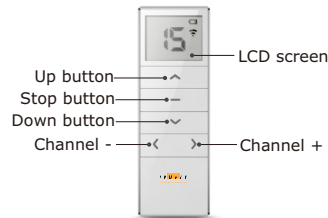

AVA-316-RF 15Ch

Setting Number of Channels Used AVA-316 15-Channel RF Remote

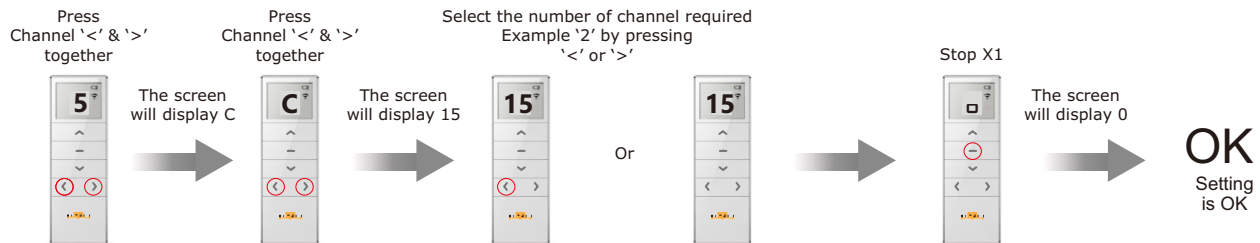

Pairing MPC-851 with AVA-316-RF 15 Ch

1. Connect motors and power to MPC according to diagram.
2. Switch on power supply.
3. Press and hold the learning button, do not release. Motor will step-move up and down
4. Wait for LED to start flashing, and then release holding the **Learning Button (Wiring Diagram - Page 2)**.
5. To pair motor 1, set the channel at the AVA-316 RF remote to "1".
6. Press the "UP" button. Motor 1 will step-move up and down. LED stops flashing. AVA-316 RF remote CH1 is now paired with motor 1.
7. To pair motor 2, repeat above step 1 to 6

** If nothing is pressed within 20 seconds, motor will revert back to working mode automatically with a step move up and down.

Details action and observation:

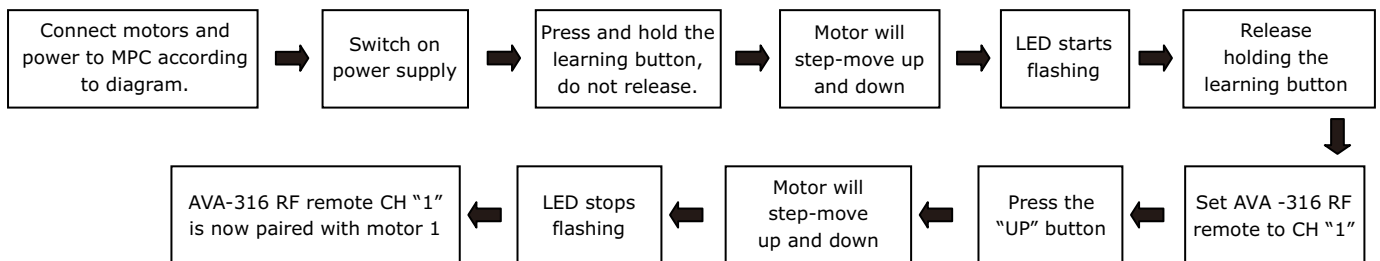

OPTION 2

Control by Network IP Address

Connecting to Network IP

- Connect MPC-852 to the local Ethernet connection
- Connect PC or Laptop or Mobile to LAN or WiFi.
Must be connected to the same network.
- Go to browser (Google Chrome recommended)
- Type in the initial IP Address is **192.168.1.200**
- Login Details
User name: **admin**
Password: **mpc852**

For more information (Website):

www.remacotech.com > Downloads > Installation Guides > Remote Controls, Electronics & Accessories > [MPC-852](#)